

2012

Recycling Furniture: The Ecological, Economic and Social Benefits

Michele Calabrese

Fordham University, env12_7@fordham.edu

Follow this and additional works at: https://fordham.bepress.com/environ_theses

Part of the [Environmental Sciences Commons](#)

Recommended Citation

Calabrese, Michele, "Recycling Furniture: The Ecological, Economic and Social Benefits" (2012). *Student Theses 2001-2013*. 33.
https://fordham.bepress.com/environ_theses/33

This is brought to you for free and open access by the Environmental Studies at DigitalResearch@Fordham. It has been accepted for inclusion in Student Theses 2001-2013 by an authorized administrator of DigitalResearch@Fordham. For more information, please contact considine@fordham.edu.

Recycling Furniture:
The Ecological, Economic and Social Benefits

Michele Calabrese

ENVP-4000
Professor van Buren
5 April 2012

Michele Calabrese

Professor van Buren

ENVP-4000

10 April 2012

Reusing and Recycling Furniture:
A Look at the Furniture Industry and More

Thesis: An analysis of the present furniture industry, environmentally, socially and economically, and a look into the benefits of recycling and remanufacturing.

- I. Introduction
- II. Furniture and the Life-Cycle Assessment
- III. Deforestation and its Effect on Climate Change
- IV. Chemicals and the 33/50 Program
- V. The Furniture Industry
- VI. Furniture Made of ...What?
- VII. Habitat and the "Total" Cost of Furniture
- VIII. Conclusion

Introduction

This summer, two of my friends and I began the Recycle Furniture organization. Our organization collects donations of furniture from various individuals in our surrounding area (Suffolk County on Long Island). We are partnered with Habitat for Humanity and tried to pick up certain pieces that the Habitat families have requested. After collecting the donations, we stored them at our local school, Islip High School, with the blessing of Principal Eileen Rossman. After we had all of the pieces we want, we refinished and restored the furniture with the help of volunteers from Islip High School. Once we completed refinishing the furniture, we plan to move it in to the Habitat for Humanity houses. This saves the families the extreme burden of having to purchase furniture.

My primary job was researching on the benefits of reusing furniture. For my thesis, we will also be highlighting the social benefits along with the environmental benefits. In this thesis, we will not only be talking about the benefits of reusing furniture, but delving deep into the furniture industry and some of the harmful chemicals used. We will discuss the chemicals and some of their effects, along with the benefits of reusing furniture. We will also be talking about the overall impact of the furniture industry to our environmental impact, mainly in climate change and deforestation. To do this, we will predominantly highlighting these issues through the disciplines of environmental physics, environmental design and sustainable business.

Before we start to deeply analyze and discuss the furniture industry, we should start off with some basic facts. In 2009, Americans produced around 243 million tons of municipal solid waste, or about 4.3 pounds of waste per person per day (EPA). Over 9 millions tons of that waste in our landfills is from furniture (EPA). This is a massive amount of waste from our furniture products. Many furniture products are created from wood, and therefore the furniture industry is one of the major industries contributing to deforestation. It is estimated that 16 million hectares a year of forest disappear (Global Change). In addition to this, only about 22% of the Earth's old growth forests still exist. Deforestation also is a major contributor to climate change. When we cut down trees, we are taking away a major carbon sink that helps curb climate change. These trees help naturally curb climate change by absorbing CO₂. We will go into this more deeply later in the paper.

Furniture and the Life-Cycle Assessment

With such a large industry, the importance of creating furniture in a sustainable fashion, free of harmful chemicals, is of the utmost important. The data discussed below highlights the fact that the reuse of furniture is not only environmentally friendly, but can result in saving companies ample amounts of money. These two factors, especially the second, are two things that must be focused on when presenting some of these ideas to companies both large and small.

To truly understand why we should refurbish furniture, we must delve into the science of it. We can do this by using the discipline of environmental physics. While environmental chemistry and biology are important tools in analyzing for environmentalists everywhere, environmental physics deals with the actual physical aspects and applications of physics. For our purposes, the major way we will be applying environmental physics is by the use of the Life-Cycle assessment (LCA). The four phases used in the LCA are material, production, distribution and use (Sahn). With the LCA we are able to tell exactly how much energy we will save by refurbishing. Material is what energy we use to process the raw materials into a “usable form”. Production is the energy used in actually producing and creating the furniture. Distribution tallies the amount of energy used in the shipping to the consumer. Use is the use of the final product by the customers. For the case of furniture, this entails repair and maintenance that can be neglected. End of life takes the energy consumed/recovered during the final stage of the product’s life. This would mean things like recycling, reuse and depositing it in a landfill.

The second way we will be analyzing the furniture is through the economic lense of life cycle costing. The life cycle costs (LCC) are analyzed and evaluated in three parts from the consumer's point of view (Sahn). The three parts of the LCC used in the study are the purchase price, use phase cost and end of life cost. The purchase price is how much we pay for the item. The use phase cost is since maintenance and repair are neglected, our use phase is assumed to contribute negligibly to the life cycle cost. End of life cost is the cost in disposing the item, whether it is reselling, recycling or any other method. For the MIT study we are using, the information was taken from a company called SteelCase Inc.

The two items used by the study were a chair composed of polished aluminum, T-arms and leather upholstery (Sahn), and a desk made with "cherry finish, cove edge, left pedestal: file/file, right pedestal: box/box/file" (Sahn). For the chair, the weight of the steel used in manufacturing was 32.3 pounds (Sahn). The weight of plastic was an additional 14.6 pounds (Sahn). Non-ferrous metals weighed in at 13.4 pounds, and leather 2.6 (Sahn). "Other" materials added another 1.7 pounds (Sahn). This gives us a total weight of 64.6 pounds.

For the desk, the primary material used was 159.3 pounds of particleboard (Sahn). Next, was 52.9 pounds of steel being used (Sahn). Third was 40.2 pounds of plywood (Sahn). Fourth was 8.6 pounds of cheery (Sahn). The final significant weight was 3.1 pounds of other woods and paper (Sahn). Another 5 pounds of the materials were made up of adhesives, finishes, backing material and plastics (Sahn).

Now that we know the weight of materials, we can discuss the actual amount of energy used to manufacture and transport these products to the customers. The

chair, our non-wood product, required 1,350 MJ, while the desk another 3,290 MJ. (Sahn). The use phase energy and consumption of these two products is negligible, so the total life cycle energy consumption is still 1,350 MJ for the chair and 3,290 MJ for the desk (Sahn). The study did not take the end of life phase into consideration because it is assumed that it is the same for the new and remanufactured product.

Next we will discuss the most important part of the study, the remanufacturing, refurbishing and the reuse energy savings potential, along with the life cycle costing. When we buy a refurbished or remanufactured item in like-new condition, no further energy is required to manufacture it, since the energy was already put in to initially create it. The same cannot be said for buying a new product, because of the energy that must be invested to create it, as we can see from our look before at the study. The major energy associated with reselling the refurbished product is the transportation cost to move it from customer to customer. In the analysis used by the study, the total life-cycle transportation energy needed was assumed equal to the new product, which is an *over* estimate according to the study. Even with this overestimate, using the remanufactured product results in energy saving. This also “holds true for the case of extending life of furniture already in use” (Sahn).

Now, we move on to the economic and sustainable business side. These are usually considered the most important factors when a business invests in a new environmental alternative. As we all know, remanufactured goods, though in many cases like new, are seen as less valuable and sold for lower prices. The price of these remanufactured goods tends to be roughly 40-60% less than the new product

(Hauser). In the study, the assumption was that the cost would be 50% less. This resulted in a 768-dollar savings for the chair (originally selling at 1799 dollars), and an 807-dollar saving for the desk (originally selling at 1890 dollars) (Sahn). We must note that both the saving values were estimated in 2000 dollars, while the original selling prices are for 2009. Though this may seem off-putting at first, it makes sense considering that the lifespan of an office chair tends to be around 10 years.

Through this study, we can see that remanufacturing furniture is a great idea for companies and households across the nation. Not only do these companies and households save money, but they also cut the demand for the amount of energy needed. By remanufacturing, we also save valuable materials that can be put to use better somewhere else. While it is important to know specific facts like we discussed above, it is also important for us to talk about some general problems our world is facing so we can know exactly what we have at stake.

Deforestation and its Effect on Climate Change

When we discuss furniture, the first thing that comes to many of our minds is wooden furniture. My grandfather himself used to run his own business that made furniture for families like the Rockefeller's. To this day, we have some of the wood left in our garage that he had used to create furniture. Sadly, some of this wood is no longer manufactured today because many of the trees used are either extinct or have such low numbers they cannot be used. Species like Honduran mahogany (*S. humilis*) and Caribbean mahogany (*S. mahagoni*) that my grandfather once used are now over-harvested and considered commercially exhausted (World Wildlife Fund). Other trees like the Cuban Ruta Tree (*Galipea ossana*) have gone completely extinct (World Wildlife Fund). As deforestation continues, the number of species affected will only continue to increase and more species of trees will be forever lost to both the manufacturing industry and our planet.

Though deforestation has certainly improved over the years, it is still a major problem in our world today. As I stated before, best estimates state that around 16 million hectares a year of forest disappear (Global Change). More disturbingly, only around 22% of the Earth's old growth forests still exist (Global Change). Deforestations' effects are seen and felt not only in the place that they occur, but all over the world.

One of the main things that comes to everyone's mind regarding deforestation is the loss of biodiversity. With this loss of biodiversity, many species end up going extinct. Since it is almost impossible to judge the exact amount of

species that go extinct, estimates vary. The UN Environment Program puts an estimate of 150-200 species of plants, insects, birds and mammals going extinct every day (Vidal). To quote Vidal, "This is nearly 1,000 times the "natural" or "background" rate and, say many biologists, is greater than anything the world has experienced since the vanishing of the dinosaurs nearly 65 million years ago." In addition, 15% of mammal species and 11% of bird species are classified as threatened with extinction (Vidal). Surely it would be idiotic to argue that humanity is not behind many of these species extinctions. While it is clear that deforestation is not the only cause of this mass extinction, it is clearly adding to the problem. Many species that go extinct may have not even discovered by scientists yet. These species are not only members of our biological community, but they also could hold benefits for society. Who knows exactly what type of medical advances some plant species in a South American rain forest may hold for humanity? It is a shame that we will have no chance to analyze, study and learn about these members of our biological community.

While the loss of biodiversity through deforestation is certainly a disturbing trend in our society today, it is sadly not the only negative effect from deforestation. As everyone with a brain knows, climate change is a major problem in today's society. While one can easily associate deforestation with remanufacturing furniture, it may not be as transparent as to why climate change can also be related. We must keep in mind that our world is one giant ecosystem and all of our activities are connected. According to a study published by the Journal Science, the world's forests absorb 2.4 billion tons of carbon dioxide each year (Foster). This 2.4 billion

tons absorbed is enough to absorb about one-third of the carbon dioxide released through the burning of fossil fuels every year (Foster). Looking at this only from an environmental economics perspective, this is a complete waste. The amount of mitigation in damage these forests would provide in regards to climate change would clearly justify the preserving of them.

During the studied period, 1990 to 2007, the research team found that established tropical forests alone capture about 1.2 billion tons of carbon dioxide a year, which accounts for 55% of the total established carbon sinks in forests (Foster). While this may sound encouraging, deforestation in the developing world is a growing problem. Nations like Indonesia and Brazil are releasing about three billion tons of carbon into the atmosphere each year (Foster). Though this may be somewhat offset by forest regrowth, which annually absorbs about 1.6 million tons of carbon, overall shifts in tropical land use, like clearing land for agriculture is still continuing to emit around 1.3 billion tons annually (Foster). These forests should be an asset in fighting climate change, but instead we are turning their positive effect into another negative effect.

Richard Birdsey, the program manager emphasized that what happens with our tropical forests can “make or break the carbon budget” (Foster). According to the study, if deforestation numbers were subtracted from the global carbon equation, established forests and their counterparts of forest regrowth could potentially capture half the carbon dioxide emitted from burning fossil fuels (Foster). Though this sounds optimistic, the extent of deforestation is “expected to get worse as humans continue to fell trees.” (Foster) This is only taking in one part

of the massive range of human activity that contributes to climate change. Activities that result in drought, fires and the spread of insects like the nefarious bark beetle only continue to wreak havoc on forests across the world. We can only hope that humanity can try to take steps to mitigate the losses that have already been dealt to our environment.

Chemicals and the 33/50 Program

Today, more than ever, we are adding chemicals to our products at a high rate. Furniture is no exception to this rule. If I had wanted to, I could have spent my entire thesis just discussing the chemicals that are released during the process of creating furniture. Some of these chemicals are harmless, but others cause great harm to the environment. These same chemicals can even remain in the owners the pieces of furniture and continue to cause harm.

The EPA developed a bibliographic report to assist wood furniture manufactures in developing “cost-effective pollution prevention practices to reduce or eliminate their releases of the 17 chemicals targeted for reductions in the EPA’s 33/50 program (EPA 33/50 Report).” For our purposes, we will be targeting only a few of this many chemicals. Before we start to talk about the chemicals, a little background on the 33/50 program is needed. The 33/50 program was the EPA’s voluntary pollution prevention initiative to reduce national pollution releases and off-site transfers of “17 toxic chemicals by 33 per cent by the end of 1992 and by 50 per cent by the end of 1995.” With the targeted set of 17 chemicals, the EPA expected a national total of 1.4 billion pounds in 1988 to 700 million pounds by 1995 (EPA 33/50 Report).

For the purpose of the report, the wood manufacturing industries were divided into three different sections. The first section was SIC 2511, called Wood Household Furniture, Except Upholstered (EPA 33/50 Report). This type of furniture included things like beds, bookcases, chairs, tables and desk (EPA 33/50

Report). The second section was SIC 2512 Wood Household Furniture, Upholstered (EPA 33/50 Report). This type of upholstered furniture on wooden frames is found on things such as chairs, recliners and couches. The final section was SIC 2521 Wood Office Furniture (EPA 33/50 Report). This group included furniture such as chairs, desks and benches.

The 17 chemicals targeted for reductions in the 33/50 programs were benzene, cadmium and compounds, carbon tetrachloride, chloroform, chromium and compounds, cyanide and compounds, lead and compounds, mercury and compounds, methylene chloride, methyl ethyl ketone, methyl isobutyl ketone, nickel and compounds, tetrachloroethylene, toluene, 1,1,1- Trichloroethane, Trichloroethylene and xylenes (EPA 33/50 report). Some of these chemicals may be familiar, others not so much, but all of them cause harm to our environment in one-way or another. For example, benzene is a known carcinogen that is known to cause leukemia (Pohanish). Cadmium is another known carcinogen that can cause respiratory tract and kidney problems, which often prove to be fatal (Pohanish). It can also make bones lose density and become softer and weaker. These are only the effects of two of these seventeen chemicals.

According to the report, the four general processes of any wood manufacturing operation are raw stock shaping, parts assembly, finishing or coatings application and unit packaging (EPA 33/50 Report). Below is an image from the document regarding the process flow diagram.

Figure 1. Process Flow Diagram: Franklin Furniture, Greeneville Tennessee

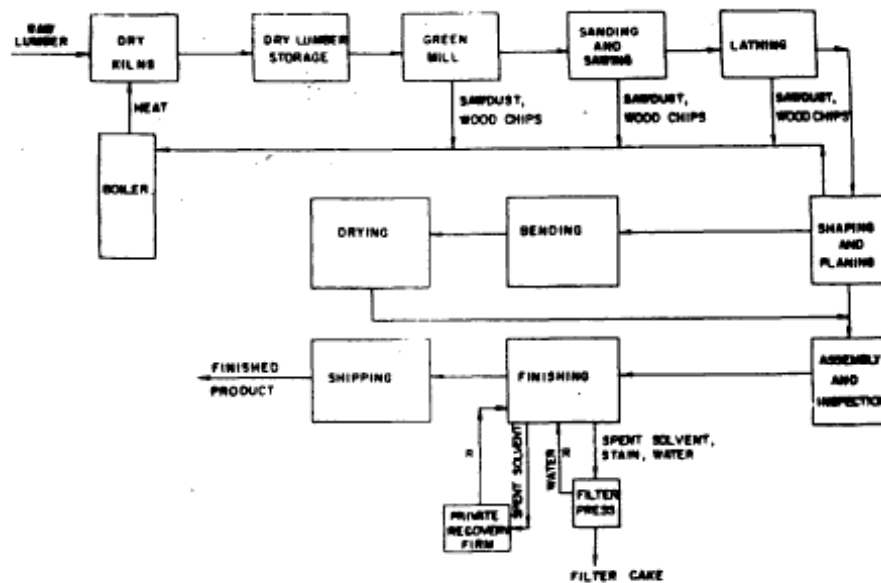

The raw stock shaping and unit packaging does not use or create any wastes regarding the 17 chemicals of concern. The actual unit packaging wastes are nonhazardous solid wastes like paper, cardboard and plastics. Finishing operations, and to a lesser extent gluing during parts assembly are the major causes of the solvent wastes and releases (EPA 33/50 Report). Finishing involves “coating, drying, and sanding the furniture in a series of repeated steps until the desired final appearance is achieved. The table below lists typical furniture operations using materials, which may generate hazardous wastes.

Table 2. Typical Operations Using Materials Which May Generate Hazardous Wastes

Typical Process/Operation	Typical Materials Used	Typical Material Ingredients	General Types of Wastes Generated
Wood cleaning and wax removal	petroleum distillates, white spirits	petroleum distillates mineral spirits	ignitable wastes, spent solvents, volatile emissions
Refinishing/Stripping	paint removers, varnish removers, enamel removers, shellac removers, paint solvents, turpentine	acetone, toluene, petroleum distillates, methanol, methylene chloride, alcohols, ketones, oxygenated solvents	ignitable wastes, ignitable paint wastes, solvent still bottoms, volatile emissions
Staining	stains	mineral spirits, alcohol pigments	ignitable wastes, spent solvents, solvent still bottoms, volatile emissions
Painting	enamels, lacquers, epoxy, alkyds, acrylics	toluene, pigments, titanium dioxide, epoxyester resins, aromatic hydrocarbons, glycol ether, halogenated hydrocarbons, vinylacetate acrylic	ignitable paint wastes, ignitable wastes, solvent still bottoms, paint wastes containing heavy metals, volatile emissions
Finishing	varnish, shellac, polyurethane, lacquers with residues	denatured alcohols, resins, shellac, petroleum distillates, toluene, diisocyanate	ignitable wastes, spent solvents, solvent still bottoms, volatile emissions
Cleaning brushes, spray gun and spray equipment, and overspray from spray booths	paint thinners, enamel reducers, varnish removers, shellac removers, white spirits	acetone, toluene, petroleum distillates, methanol, methylene chloride, isopropanol, mineral spirits, alcohols	ignitable paint wastes, ignitable wastes, spent solvents, solvent still bottoms, volatile emissions
Gluing, cleaning adhesive application equipment	Adhesives	methyl isobutyl ketone, methyl ethyl ketone, xylene, toluene, 1,1,1-trichloroethane	volatile emissions

Source: Tennessee Hazardous Waste Minimization Program.

Solvents are used in everything from stains to paints to finishes. The solvents used in finishing operations are typically a “complex blend of different types of solvents.” In addition they are used to strip earlier coatings from some pieces prior to their recoat. Finally, further solvents are used for cleanup

operations. As you can tell from this detailed process, these solvents are used freely throughout manufacturing.

To reduce pollution, the EPA used methods like production planning and sequences, process or equipment modification, raw material substitution or elimination, loss prevention and housekeeping, waste segregation and separation, closed-loop recycling and training and supervision. While these steps may sound simple, it is sometimes the simple choices that make the largest difference.

For our purposes, we will discuss the recycling and reuse aspect of the program. The report includes a description of the process and then the examples of cost and savings. We will discuss some of the instances, but also refer to the table below.

Recycling and Reuse		
Solvent Recycling	Capture solvent emissions from gluing for reuse. Methods include use of activated carbon or condensers, membrane system, Brayton cycle heat pump, polymer absorption.	Membrane system, Brayton cycle heat pump, polymer absorption are emerging technologies and have not yet been proven. [Reference #20]
	Recycle spent solvents with recovery units including:	Annual cost savings: \$5,700. Payback period: 1 year. [Reference #4]
	<ul style="list-style-type: none"> ● small on-site solvent recovery stills to recycle spent lacquer thinner. 	
	<ul style="list-style-type: none"> ● small in-house stills to recycle methylene chloride. 	Payback period: 2 years. Incentive was to avoid RCRA liability related to disposal. [Reference #4]
	<ul style="list-style-type: none"> ● in-house stills to recycle xylene. 	Payback period: 13 months. [Reference #4]

As we can see from the table, solvent recycling is an extremely effective method. The recycling spent on solvents with recovery units had an average saving of 5,700 dollars and a payback period of 1 year (EPA 33/50 Report). The other two

methods of solvent recycling had payback periods of 2 years or less (EPA 33/50 Report). This is an acceptable amount of money to save with a fairly quick payback period for a business. The next page of the document gives us another ten methods and descriptions, but for the issue of space, we will not discuss all of them. I have inserted the graph as reference to show the descriptions and successes of the project.

Table 3. Examples of Source Reduction and Recycling Options for Finishing and Gluing Operations (continued)

Types of Techniques	Description	Examples of Costs and Savings and Other Information*
Recycling and reuse (continued)	<ul style="list-style-type: none"> batch distillation units to recover xylene from paint equipment cleanup. 	Payback period: 13 months. Annual savings: \$5,000. [Reference #8, p. 18]
	<ul style="list-style-type: none"> recovery system for solvents contained in air emissions. 	Annual savings: \$1,000. [Reference #8, p. 10]
	<ul style="list-style-type: none"> batch distillation units to recover isopropyl acetate generated during equipment cleanup. 	Payback period: 2 years. [Reference #8, p. 17]
	<ul style="list-style-type: none"> small solvent recovery stills to recover spent paint thinner from spray gun cleanups and excess paint batches. 	Capital investment: \$6,000 for a 15 gallons capacity still. Annual savings: \$3,600 in new thinner savings; \$5,400 in disposal savings. Payback period: less than 1 year. Waste Savings/reduction: 75% (745 gallons of thinner recovered from 1,003 gallons). Product/Waste throughput information: 1,500 gallons of spent thinner processed per year. [Reference #8, p. 6]
	<ul style="list-style-type: none"> a methyl ethyl ketone solvent recovery system to recover and reuse waste solvents. 	Annual savings: \$43,000/year; MEK recovery rate: 20 gallons/day, reflecting a 90% reduction in waste. [Reference #9, p. 7]
	Arrange an agreement with other small companies to jointly recycle cleaning wastes.	Reference #1 & #6
	Develop cooperative recycling with other facilities in area to make distillation economically viable for all participants.	Reference #1 & #6
	Recover and reuse cleanup solvents for cleaning operations or with a compatible coating operation.	
	Modify spray booth to allow recovery and reuse of overspray solids.	
	If possible, return extended shelf life items to the manufacturer rather than disposal; if manufacturers won't take the items they may be sold or donated as a raw material.	

The 33/50 program ended up meeting its goal of 50% reduction one year early (EPA Final Record). When 1995 came around, releases and transfers ended up totaling 672 million pounds, and by 1996 the releases and transfers fell to 601 million pounds (EPA Final Record). This represented a 60% drop off (EPA Final Record). In other words, the program was a complete success. Reductions even continued at a higher rate for 33/50 chemicals than for other TRI chemicals in the year after the 33/50 Program ended. Though this program may be fifteen years old, it proves that we can have success with making the furniture industry greener through both the reuse and recycling of chemicals and products. We can only hope that programs like this continue to be successful for our country and across the world.

The Furniture Industry

The U.S. furniture industry tends to grow around 7 to 8 percent a year (Schuler). From 2006 to 2007 the industry only grew 3 percent (Schuler). The total value went from 84.6 billion dollars in revenue to 87.1 billion dollars (Schuler). Though no further data is available on this at the present time, there is no doubt that this number has continued to grow in the past five years.

One of the major users of furniture across America are offices. According to the United States Census Bureau, the total value of office wood furniture was 2.8 billion dollars in 2002 (US Census Bureau). In addition to that, the non-wood furniture value was around 7.8 billion dollars in 2002 (US Census Bureau). This is a combined value of over 10 billion dollars in furniture in offices across America (US Census Bureau)

Throughout this paper, we have focused on the benefits of recycling and remanufacturing furniture. It is clear that there are not only environmental benefits from this process, but also monetary and social components. Now we must ask ourselves exactly what is going on in the furniture industry today. We have discussed some of the chemicals that are released, but now it is time to discuss the actual business end of the furniture industry itself. We previously discussed the process of building wood furniture in the 33/50 Program section, but this section will go into more details of the world of furniture manufacturing as a business. After all, an over 80 billion dollar American industry is a major part of our economy. For this analysis, we must use an economic thought process.

While we may have many great environmental improvements that a business can follow, it is important to know exactly what state the business is in to afford some fixes. After all, many environmentally efficient alternatives are costly in their early years, but pay back dividends as time goes on. This makes it necessary for us to analyze the business end of the industry. Regardless of how effective an environmental initiative might be, it is useless to a business if they cannot afford it. Since the industry has many companies, we will be comparing the American manufacturing industry as a whole vs. the new Asian manufacturing industry.

As with many of American industries today, the furniture industry is struggling. Over the past ten years, Asian furniture markets have devastated the U.S. wood furniture market (Shoucair). This comes predominately from the fact that the high cost of conventional wood manufacturing in the United States has made it almost impossible to compete with the volume of low-cost Asian furniture that has flooded the market (Shoucair). The pressure from the imports has also affected the upholstery business. From 1992 to 2005, imports of all furniture products went from 4.1 billion dollars to 23.65 billion dollars (Schuler). This amount is almost an increase of 20 billion dollars. That is a 477 percent increase (Schuler). China's imports alone increased from 208 million to 10.8 billion, a fifty-fold increase in 13 years.

Once the recession hit, "unfavorable comparisons soon become sizable losses and stock prices nosedived, forcing many outfits to reevaluate their business strategies and substantially reduce capacity" (Shoucair). This meant a massive restructuring and many companies accepting that they could not compete head to

head with Asian wood furniture manufactures. Companies like Ethan Allen and La-Z-Boy began widespread plant closures, retail location closures and other cost-cutting measures (Shoucair).

From 1997 to 2005, the American furniture industry lost 108,000 jobs, or around 21 percent of its work force (Schuler). The only two sectors within the U.S. furniture industry that showed growth were kitchen cabinets and office furniture (Schuler). Between 1997 and 2005, the value of shipments for kitchen cabinets went up 111 percent, and the value of office furniture shipments increased 22 percent (Schuler). Another interesting fact was the increase of upholstered furniture shipments 27 percent and the decrease in business of nonupholstered furniture (wood), which fell seven percent (Schuler).

While many thought this might have been the deathblow to the American furniture industry, it was not. One factor that allowed these companies to survive is the “need to differentiate product offerings by quality” (Shoucair). Premium brands, like Ethan Allen and La-Z-Boy are expected to have superior quality and customization over foreign competition. With this, many companies have decided to diversify product categories and pricing tiers in “order to set apart premium lines and establish a sense of prestige that may appeal to the less thrifty consumer” (Shoucair). Germany has taken a similar approach in its technology industry and has thrived by using quality as a measurement of success instead of cost.

Many of the companies have been able to adapt and survive this changing environment. Now, heavy plant consolidation and capacity reduction have streamlined operations and made the furniture manufactures more agile. In regards

to the residential end of the furniture manufacturing spectrum, many have opted to outsource the lion's share of wood furniture production and adopt a quality-driven, retail-oriented approach that puts an emphasis on better service, more efficient distribution, technological advances and more effective marketing initiative (Shoucair). Regardless of the commodity inflation that has increased raw-material costs, it has demonstrated "greater liquidity and widening margins" (Shoucair). With our improved economic climate, the industry has unlocked some "pent-up demand", which has lifted and enhanced pricing power, as the widespread discounting has begun to subside.

Within the commercial end, diversification has been a major strategy. Since commercial construction stalled during the recession and has yet to rebound, most commercial furniture companies have widened their respective revenue bases. The expanded marketing efforts have created more customers from the healthcare, government and education sectors (Shoucair). Most importantly, the cash preservation measures have left many corporations flush with cash, and made a higher spending on refurbishing existing office space with new furnishings, instead of expanding and opening up new locations. This is an area that could clearly be improved by using refurbished furniture, since it is better to furnish one existing office space with new furniture than buying double the new furniture for two locations.

Since this revolution has only happened over the past few years, we have yet to been able to see the complete effects on the environment. It should be interesting

to see exactly what the environmental effects of this new method of furniture manufacturing will be in years to come.

In the end, most companies in the furniture sector have put themselves in a position to sustain positive sales and earn momentum once volatility subsides. According to Shoucair, he believes that “it will not be smooth sailing, but this sector, in its greatly transformed state, has likely seen the worst of its woes”. We can hope that with this new improved quality furniture combined with the prospect of better economic times, the furniture industry can continue to improve its environmental record. It is always important to understand the economic times before any major environmental changes occur. Another program like the 33/50 may just be years away from changing the industry forever. In our next section, we will be discussing different sustainable and environmentally friendly alternatives to what is currently being used in the furniture industry.

Furniture made out of What?

One of the new developments today is the idea of furniture being made out of different materials. When we traditionally think of furniture, we think of items made out of things like wood, leather and cloth. For this section we will be discussing alternative materials used in furniture. We will be talking about whether this is a new fad, or something that can become an environmental trend in the furniture of our future.

As we talked about before, many different trees are no longer commercially viable or have become extinct because of extensive logging. One of the forerunners in environmentally friendly furniture material today is bamboo. Some may think of bamboo as a flimsy material, but it is actually as strong as teak or wood composite and can last up to twenty-five years (Orr 78). Even more useful, is the materials ability to be extremely malleable compared to most woods. Similar to bamboo, is rattan. Rattan is a palm, which is often woven into wicker, and as a source, "it is much faster growing than wood, thus making it a protector of forests when harvested" (Orr 78). Like bamboo, rattan is lightweight flexible and durable. Though these two materials are both wood, they are more eco-friendly and it is easier for these two plants to grow than a typical tree.

Green furniture is a very broad term. Many companies claim that their furniture is "green", but how is a consumer to know which companies are green, and which ones are pretending to be green? In the green furnishing industry the two large names in verifying the sustainability of products are The Sustainable

Furnishing Council (SFC) and the Forest Stewardship Council (FSC) (Matthews). The SFC “provides clarification and resources on furniture that is green, eco-friendly, environmentally safe and sustainable” (Matthews). They are considered the number one organization in green furnishings and are composed of a non-profit coalition of suppliers, manufactures, retailers and designers formed to “promote sustainable practices with the best networking and education in the industry” (Matthews). The SFC even has a live 6-hour training program, which is the most comprehensive training program available.

The main mission of the Forest Stewardship Council is to “help reduce the environmental impact of harvesting wood, including furniture made from wood” (Matthews). The FSC gives members a certification to “improve the practice of forestry by reducing the negative impact of logging through managing and protecting forests” (Matthews). While these two may be the primary names in verifying sustainability, it does not mean that they have completely succeeded. Many furniture manufactures are still waiting for legislation before they decide to become more sustainable.

There are also many sites where information about green furniture is readily available. Two websites of note are Inhabitat.com and Inmod.com. [Inhabitat](http://Inhabitat.com) is predominantly a news source regarding the development of green furniture. The site contains many stories about some of the new cutting edge movements in the furniture. On the other hand, [Inmod](http://Inmod.com) also has information, but mainly focuses on selling the furniture itself.

While bamboo and rattan are interesting materials that have only recently become popular in America, they have been used in other areas like Asia for a long time. A new popular trend in furniture is the reuse of plastic. In 2010, the United States generated 31 million tons of plastic waste, representing 12.4 percent our total municipal waste (EPA). This is not including products that get recycled. Almost 14 million tons of this plastic was just from containers and packaging. Since plastic takes such a long time to decompose and kills many animals, it is clearly not environmentally friendly. Sustainable businesses like Poly-Wood and Loll Designs have their entire collection made from post-consumer recycled plastic, an environmentally friendly alternative to normal plastic. Instead of this plastic going to waste, companies like this are able to make a positive use of the plastic and are able to make a profit at the same time. These companies also cut down on the fossil fuels emissions from shipping raw materials, like the wood received from all over the world for manufacturing, from one place to another. While we have all seen homes made of recycled plastic bottles, this is clearly a process that is likely to be mainstreamed. On the other hand, using recycled plastic for furniture is something that is already succeeding and will most likely continue. Many of these companies are able to purchase the post-consumer plastic at a fraction of what they would normally pay for materials. This process seems to be one of the more optimistic futures of furniture.

Habitat and The “Total” Cost of Furniture

Habitat for Humanity has been helping families across America since 1976. Founded by Millard Fuller and his wife, it is a “nonprofit, ecumenical Christian housing ministry that has helped build over 500,000 decent affordable houses and served 2.5 million people worldwide” (Habitat for Humanity). Though Habitat for Humanity’s headquarters is located in Georgia, Habitat has a foothold in communities worldwide. The international office of Habitat for Humanity is controlled by a board of directors who are looking to alleviate the problem of housing poverty across the world.

Habitat for Humanity works primarily through volunteer labor and donations of money and materials. For the people receiving the home, they must invest hundreds of hours of their own labor into building not only their own house, but houses for other Habitat for Humanity families. They are also required to make a down payment and pay the monthly mortgage rates. The acceptance of a family into the program is determined by committee based on need and the family’s willingness to help in the program. Through this, Habitat for Humanity hopes to complete their vision of “a world where everyone has a decent place to live” (Habitat for Humanity).

While Habitat for Humanity is kind enough to help build these people a home, they cannot do everything for them. This is where our organization, Recycle Furniture, comes in. After talking with Habitat for Humanity, we get in contact with the families who are having their homes built by Habitat. From the families, we get

a list of the general type of furniture that they are each looking for, and try to cater what we find for each family. All of our furniture is stored at our local high school, Islip High School, and in donated storage units by a local storage facility. Once we have reached our quota, with the help of Islip High School Students, we refinish the furniture using environmentally friendly alternatives instead of products like the normally toxic lacquer and varnish. We just moved our first family, a mother and her three children, a little less than a month ago with beds, mattresses, a couch, a kitchen table and chairs and a few other pieces of furniture. Now, we are waiting to deliver the rest of our furniture to the chosen families once the other Habitat for Humanity homes are finished.

We created our organization because we realized that furniture is something that everyone needs in their home. While the amount of furniture may vary, everyone at least needs a few things to get by in their home. We wanted to be able to put a dollar amount on exactly how much we are saving these people to show just how much of a burden furniture can be. For our baseline, we decided that we would only accept new furniture. In addition, this new furniture will be the most affordable that IKEA has to offer, a popular furniture store that many Americans and people across the world tend to buy from. This does not necessarily mean this furniture is quality, but it will “get the job done.” Since Habitat for Humanity has built over 500,000 homes and served 2.5 million people worldwide, we will use the average number of members in the family as 5 for our numbers.

The first room that we will analyze the cost for is the living room. From IKEA, the cheapest sofa available is a KLOBO loveseat for 180 dollars (IKEA). Since

we are analyzing a family of five, we will need another three chairs, priced at 30 dollars each. For a side table and a table lamp, the cost is another 21 dollars (IKEA). The most affordable rug is 10 dollars, and another 5 dollars is needed for a ceiling lamp (IKEA). Finally a TV table or wall bracket is another 20 dollars (IKEA). For these basic pieces of furniture the total is 326 dollars. With New York State sales tax the total comes to 353 dollars. This cost does not include something like a television that almost every American has in their living room.

Assuming that the family has only one living room, we will now move on to the costs for the bedrooms. Since it is a family of five, let us figure that the parents have their own room, while two children share a room and the other has their own. For the room with the one child in it, a twin bed frame, mattress and mattress pad total 137 dollars (IKEA). Add in a blanket, pillow protector, pillow, duvet cover and pillowcases and the total is 57 dollars (IKEA). Finally we add in a rug, nightstand, ceiling lamp and table lamp. The total comes to 231 dollars. For the room with two children, the total would be 209 dollars per child if they each had their own nightstand and table lamp. Combine these three costs together and we have 649 dollars. If we add in New York State sales tax, the total to furnish three bedrooms for a family of five is 704 dollars.

Now when we combine both the bedroom and living room costs together, we have a total of 1057 dollars. This is using the *cheapest* furniture available at IKEA. It is not uncommon for families today to spend that amount on just a couch. Through our organization, we are not only saving the family's money, but also reducing the environmental impact of producing new furniture. Though currently only focused

on Suffolk County on Long Island, we hope to enlarge our program and expand our reach.

Conclusion

Furniture is an extremely complicated, diverse and interesting topic, though it may seem bland at first look. The tendrils of this over 80 billion-dollar American furniture industry reach from deforestation, to climate change and even to the government level. We have seen successful regulation programs like the 33/50 program succeed in helping reduce some of the harmful chemicals released during the manufacturing process. It is essential to place the emphasis on the three R's of reduce, reuse and recycle to help the problems of the furniture industry.

It is hard to form only one takeaway from our discussion. Since this is such a large reaching problem, there is clearly no one step that can be taken to fix it. This is why it is so essential to remember the three R's. It would be naïve and ignorant to say that if we stopped manufacturing plastic that our problems would go away. We have seen from companies like Poly-Wood and Loll Designs that even plastic can be turned into a positive. Since businesses like the beverage industry and food industry continue to use plastic for packaging, it is important that companies like Loll Designs and Poly-Wood exist to try and recycle this material. Though they are only two companies, it would not be a shock if companies like this continue to grow as they see the demand for environmentally sustainable furniture. Hopefully more companies can continue to be responsible like these two.

Through our readings of the MIT study, we have seen that it is not only more energy efficient to refurbish furniture (40-60%) but cost efficient. Of course many businesses want to sell customers and companies new furniture, but if businesses

continue to pop up offering refurbishing, the other businesses will meet the market's demand. At the end of the day, we must realize that a more informed consumer is the best tool in creating a more environmentally friendly furniture industry, and on a whole a more environmentally friendly world. If people demand refurbished furniture, the market will meet that demand.

Our organization of Recycle Furniture is another example of how refurbished furniture can not only make an environmental difference but a social one. The organization is not only able to make an impact by refurbishing used furniture through environmentally friendly methods, but also a societal one by giving furniture to those families who need it. With these burdens lifted, these families can spend their money on other alternatives and not have to use it on less environmentally friendly alternatives. Though it is a small nonprofit organization, it has made an impact in our community and we hope that we can continue to help and even expand the reach of the organization.

With the looming threat of climate change, deforestation is clearly an issue that needs to be addressed. Wood furniture is something that needs to be addressed as we continue to move on. As alternatives like bamboo and rattan may be in the future for more companies. It is not bad enough that we are losing over 100 species a day to extinction, but we are also losing a natural carbon sink that can absorb one-third of the carbon dioxide emitted by fossil fuels every year. If we continue to deforest our Earth, the problem of climate change and its effects will only become more rampant.

If we are to take away one thing from this thesis, it is that there are ways already out make furniture a more environmentally friendly product. Whether it is reusing and remanufacturing furniture, or building furniture out of recycled materials, it is a step in the right direction that more companies must strive for. By simply remembering the three R's, companies can help create a cleaner product. When consumers continue to demand a more environmentally responsible product, manufactures will meet that demand. As the consumer demand hopefully rises, we can strive towards a more environmentally friendly furniture product, and a healthier Earth.

Works Cited

Environmental Protection Agency. *Municipal Solid Waste Generation, Recycling, and Disposal in the United States: Facts and Figures for 2010*. Rep. Environmental Protection Agency, 2010. Print.

Foster, Joanna M. "As 'Sinks' for Carbon, Forests Are Even Mightier Than Assumed." *Green Blog*. New York Times, 15 July 2011. Web. 10 Apr. 2012. <<http://green.blogs.nytimes.com/2011/07/15/as-carbon-sinks-forests-are-even-mightier-than-assumed/>>.

"Habitat for Humanity Fact Sheet (frequently Asked Questions)." *Habitat for Humanity Int'l*. Habitat for Humanity, 20 Dec. 2011. Web. 10 Apr. 2012. <<http://www.habitat.org/how/factsheet.aspx>>.

William Hauser and Robert T. Lund. *The remanufacturing industry: Anatomy of a giant*. 2003.

"Home Furnishings, Kitchens, Appliances, Sofas, Beds, Mattresses - IKEA." *Welcome to IKEA.com*. IKEA. Web. 10 Apr. 2012. <<http://www.ikea.com/us/en/>>.

"Mahogany Trades FAQs." *Wildlife Trades*. World Wildlife Fund, 01 Apr. 2012. Web. 04 Apr. 2012. <<http://www.worldwildlife.org/what/globalmarkets/wildlifetrade/faqs-mahogany.html>>.

Matthews, Richard. *The Green Market*. Blogspot, 20 Jan. 2011. Web. 22 Mar. 2012. <<http://thegreenmarket.blogspot.com/2011/01/state-of-sustainable-furniture-industry.html>>.

Orr, David W. *The Nature of Design: Ecology, Culture, and Human Intention*. New York: Oxford UP, 2002. Print.

Pohanish, Richard P., and Marshall Sittig. *Sittig's Handbook of Toxic and Hazardous Chemicals and Carcinogens*. Norwich, N.Y., U.S.A.: Noyes Publications, 2002. Print.

"Pollution Prevention Options in Wood Manufacturing." *National Service Center for Environmental Publications (NSCEP)*. EPA, Feb. 1992. Web. 10 Apr. 2012.

<<http://nepis.epa.gov/Exe/ZyNET.exe/910135PX.txt?ZyActionD=ZyDocument&Client=EPA&Index=1991%20Thru%201994&Docs=&Query=&Time=&EndTime=&SearchMethod=1&TocRestrict=n&Toc=&TocEntry=&QField=&QFieldYear=&QFieldMonth=&QFieldDay=&UseQField=&IntQFieldOp=0&ExtQFieldOp=0&XmlQuery=&File=D%3AZYFILESINDEX%20DATA91THRU94TXT0000027910135PX.txt&User=ANONYMOUS&Password=anonymous&SortMethod=hj-&MaximumDocuments=1&FuzzyDegree=0&ImageQuality=r75g8/r75g8/x150y150g16/i425&Display=p|f&DefSeekPage=x&SearchBack=ZyActionL&Back=ZyActionS&BackDesc=Results%20page&MaximumPages=1&ZyEntry=5>>.

"Program Goals Met and Exceeded." *33/50 Program: The Final Record*. EPA, Mar. 1999. Web. 08 Mar. 2012. <<http://www.epa.gov/opptintr/3350/33fin02.htm>>.

"Refinishing Furniture, Restoration, On-Site Upholstery, Furniture Restoration Environmental Impact - Therefinishingtouch.Com." *Furniture Restoration, On-Site Furniture Refinishing, Upholstery, Hotel Furniture, Armoire Modification at Discount Price at Therefinishingtouch.com*. Web. 20 Jan. 2012.

<http://www.therefinishingtouch.com/impact_env.html>.

Sahn, Sahil, Avid Boustani, Timothy Gutowski, and Steven Graves. *Furniture Remanufacturing and Energy Savings*. 28 Jan. 2010. Web. 17 Jan. 2012.

Schuler, Al. "The U.S. Furniture Industry." *Lurko of America*. Lurko of America, 15 Dec. 2012. Web. 10 Apr. 2012.

<https://docs.google.com/a/fordham.edu/viewer?a=v&q=cache:cMjjwmlNz0cJ:www.turkofamerica.com/index2.php?option%3Dcom_content%26do_pdf%3D1%26id%3D59+&hl=en&gl=us&pid=bl&srcid=ADGEEsGn-6CzyIDB00xQGYGhHjb2NwpNiE-jY6f5pd8u1JoChXa99IrijV3AD19ad-EBdSF2_4Caxdj3_wwwy5Kj5iFZdUCQEREIyUwo--AH7LYBDGnRHGoGTAVG1wKNds7CF-fadkBF&sig=AHIEtbQhN2rEjdn4jWM9X2ZAxNsFS3I5AQ>.

Shouair, Simon. "Research Hub." *An Analysis of the Future of the U.S. Furniture Industry*. Value Line, 24 July 2011. Web. 5 Mar. 2012.

http://www.valueline.com/Stocks/Commentaries/Does_U_S_Furniture_Have_a_Le_g_to_Stand_On_.aspx

SteelCase Costs. SteelCase Wed. February 15. <http://www.csnstores.com/steelcase-ts5tlb24272-sca1137.html#proddetails>.

US Census Bureau. Wood office furniture manufacturing: 2002. 2002 Economic Census, 2002.

Vidal, John. "Protect Nature for World Economic Security, Warns UN Biodiversity Chief." *Biodiversity 100*. The Guardian, 16 Aug. 2010. Web. 3 Apr. 2012.
<<http://www.guardian.co.uk/environment/2010/aug/16/nature-economic-security>>.